

# TurboCAD Pro V15.2 – Railcar Truck

Working on the Edge of Complexity

Donald B. Cheke

HRI Railcar Truck Overview

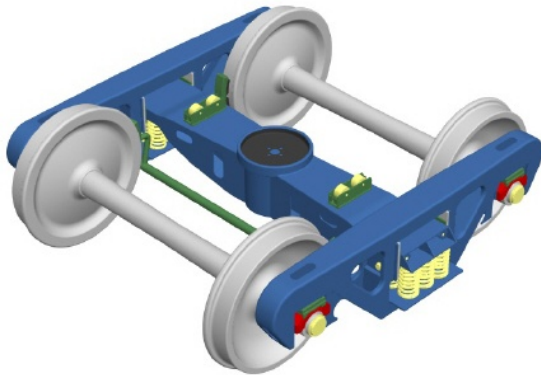

HRI Railcar Truck Exploded View

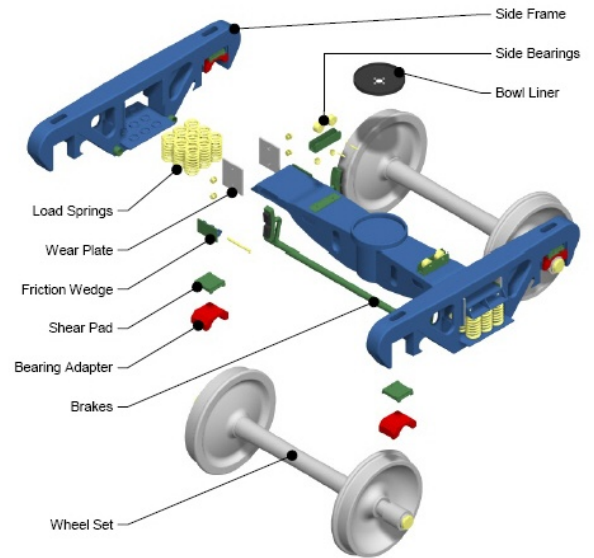

HRI Railcar Truck  
Model 5719a

Drawing by Donald B. Cheke  
Textual Creations - Saskatoon, SK

1 of 2



HRI Railcar Truck  
Model 5719a

Drawing by Donald B. Cheke  
Textual Creations - Saskatoon, SK

2 of 2

---

Copyright © 2009 Donald B. Cheke

TurboCAD is a registered trademark of IMSI/Design.



Published by:

Donald B. Cheke  
Saskatoon, SK Canada

Visit: [www.textualcreations.ca](http://www.textualcreations.ca)

---

All rights reserved

No part of this document may be reproduced, copied, stored on a retrieval system or transmitted in any form without written permission from the author. The purchaser may, however, print one copy of the document to paper and may make one backup copy of the downloaded material for personal use only.

#### Limitation of Liability

While every effort has been taken in the preparation and the writing of this document the author assumes no responsibility for errors and/or omissions nor for the uses of the material and the decisions based on such use. No warranties are made, express or implied with regard to either the contents of the document, its merchant ability or fitness for a particular purpose. The author should not be liable for direct, indirect, special, incidental or consequential damages arising out of the use or inability to use the contents of this document.

#### Special Note

All of the work presented within this tutorial is based on TurboCAD Pro V15.2. Although users of previous versions are welcome to try the tutorial it cannot be stated what results will be achieved. Many changes, some subtle and others not so subtle, are made with each program revision. Although many steps and directions would be generic some may not be. The same can be said for tools between versions. Older versions may not have the same tools as Pro V15.2 and if the same tools are available the tools themselves may have been revised and hence, work in a different manner than they previously did.

## Table of Contents

Table of Contents.....	3
Introduction .....	4
Setup.....	6
Initial Lighting.....	13
Track Profiles.....	18
Wheel Profile .....	27
Axel Profile.....	39
Axel & Wheel Profiles to 3D.....	43
Side Frame Profiles.....	45
Bearing Adapter & Shear Pad Profiles.....	55
Side Frame, Bearing Adapter & Shear Pad Profiles to 3D.....	58
Spring Plate & Wear Plates .....	94
Spring Set.....	96
Bolster .....	116
Friction Wedge .....	133
Side Bearings, Bowl Liner & Brakes .....	142
Materials Application .....	150
Named View.....	161
Render Scene Luminance .....	164
Saving the Rendered Image (1).....	168
New File Adjustments .....	171
Saving the Rendered Image (2).....	175
Exploded View .....	176
Saving the Rendered Image (3).....	183
Additional View.....	183
Paper Space .....	183
Pre Printing.....	204
Complexity Tweaks.....	205
Printing.....	208
Alternate Methods.....	209
Appendix – An Important Note about TurboCAD Materials.....	210

## Introduction

It is a fact that a TurboCAD user will occasionally find a need to create a model that challenges the program and the user. The program, because only so much memory is allowed per application (~1.6GB using Microsoft XP) and TurboCAD can hit that wall without too much trouble. The user, because they are faced with the challenge of creating the parts in a manner that is file size friendly while being visually appealing at the same time.

With only a couple dozen parts, and most of them blocks, it may come as a surprise to the reader that creating a two page layout of the railcar truck does not come without issues. The issues arise due to the complex nature of some of the parts. This includes such things as the load springs, the side frames, the bolster and even the wheels with their rounded edges. Although the reader will be exposed to these issues, the author does lead the reader through alternate methods and/or fixes that do allow the project to be completed in a pleasing manner. Ideas are also offered about what to do when the program simply can't deliver what the user requires.

The railcar truck is an interesting industrial product and one that provides an ideal modeling challenge. It presents some interesting shapes that require some forethought and planning. Within the tutorial the reader will be lead through each keystroke to produce almost every component of the railcar truck that is illustrated on the cover of the tutorial. The brakes, side bearings and bowl liner are provided by the author and are inserted into the drawing in a manner that one might do if they were getting parts from an associate or from an online vendor. The reader will learn how to create the various components using 2D profiles and modified 3D primitive shapes. The reader will learn how to insert standard lighting and how to utilize render scene luminance. The reader will learn how to render their drawing and save it in a high resolution image format. Additionally, the reader will learn how to use Paper Space to create a two page presentation.

This tutorial is in no way intended to teach industrial design or construction, but rather it is intended to teach the use of some of the tools that TurboCAD has to offer and to introduce the new user to a drawing methodology. The author feels confident that the techniques outlined within the tutorial can help lay the foundation for future successful TurboCAD drawing and illustration for even the newest user.

As with any technically advanced software, the user is generally faced with a steep learning curve. It is the hope of the author that the money and time spent working through a Textual Creation tutorial will help ease the learning and allow the reader to come away feeling confident that they made a wise decision.

This tutorial will assume that the reader has the full edition of TurboCAD Pro V15.2 with the current Architectural and Mechanical add-ons, although no architectural or mechanical add-on tools will be used during the tutorial that the author is aware of.

There are many ways to approach a project and it is likely that each person using the program would proceed in very different ways, so be open to alternative methods as experience builds. What is important is that the user becomes familiar with the objects that they wish to model and begin to look at them in a different way than they might otherwise do. What primitive shapes make up the whole? What will be required of these primitive shapes early in the drawing and how will this affect needs further along? What component or components should be started with? Many questions can only be answered through experience, but hopefully some of them will be answered by the time the beginner has worked through this tutorial. There is a great deal covered in this tutorial and the author urges the beginner to be patient, to read very carefully and to take the time necessary to do a good job. Try to enjoy the process as much as you will enjoy the final results.

This tutorial assumes that the beginner has studied the desktop to some degree and can locate most of the tools. Since there are endless desktop configurations that can be set up in TurboCAD the author has

opted to illustrate the required tools with the V15 user interface, and the default toolbars in their undocked format (Office 2000 theme).

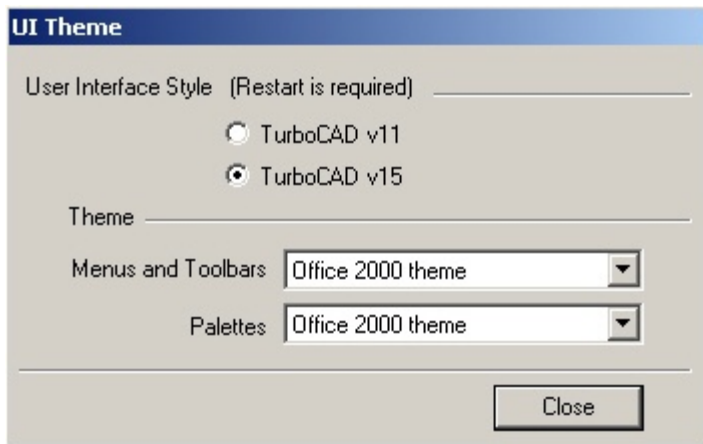

Please remember that any supplied images and files are for use within the tutorial only and may not be shared or sold to others.

The beginner should not overlook the importance of the internet as a resource for material to help understand the dynamics of what they are trying to model. If only to help gain a better understanding of what a user is modeling a Google image search and regular web search is time well spent.

Select the upper blue line and the red wheel profile. Tab into the Inspector Bar and enter **-.15** in the Delta X field. Press Enter to move it over a bit.

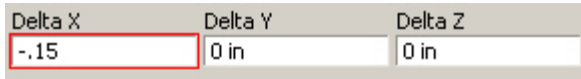

Select the Fillet tool from the Modify toolbar.

Tab into the Inspector Bar and enter **.25** in the Radius field. Press Enter. Be sure that the To Polyline option is engaged.

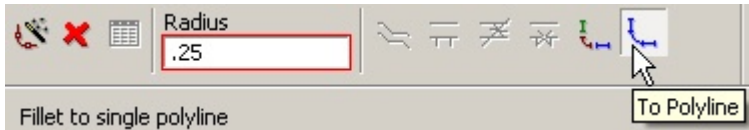

Using left mouse clicks on the lines that comprise the corners, fillet the five corners, as indicated in the picture below.

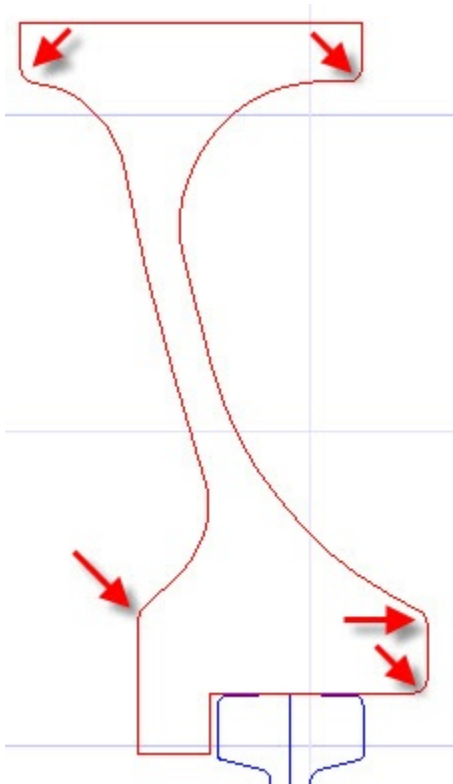

Tab into the Inspector Bar and enter **.5** in the Radius field. Press Enter. Be sure that the To Polyline option is engaged.



Using left mouse clicks on the lines that comprise the corners, fillet the three lower corners, as indicated in the picture below.



## Axel Profile

A quarter axel profile will now be created – working towards the image below.

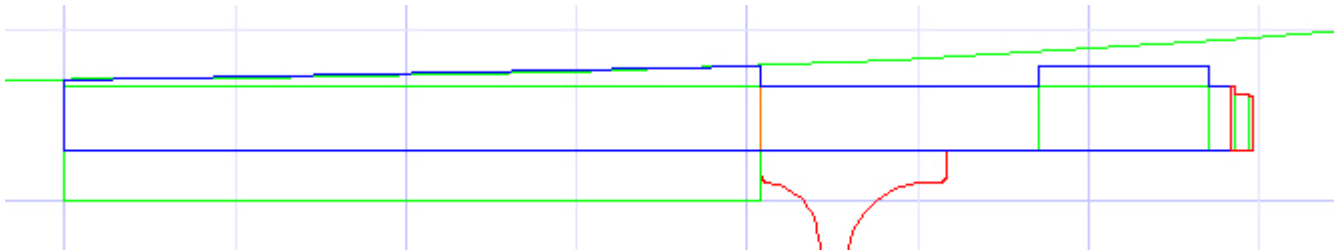

Select the Rectangle tool from the Line toolbar.

Select Green from the color dropdown menu on the Property toolbar.

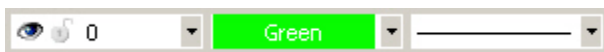

V SEKE snap the upper left corner of the wheel profile to place the first point of the rectangle. Move the cursor in a left downwardly direction and then G SEKE snap the next point of the rectangle at  $X = 0$ ,  $Y = 24$ .



V SEKE snap the top left corner of the last rectangle to place the first point of the next rectangle. Move the cursor in a right upwardly direction for a short distance and then Tab into the Inspector Bar and enter 41 in the Size A field and 2.25 in the Size B field. Press Enter.

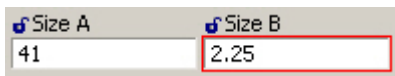

V SEKE snap the lower right corner of the last rectangle to place the first point of the next rectangle. Move the cursor in a left upwardly direction for a short distance and then Tab into the Inspector Bar and enter 6 in the Size A field and 3 in the Size B field. Press Enter.

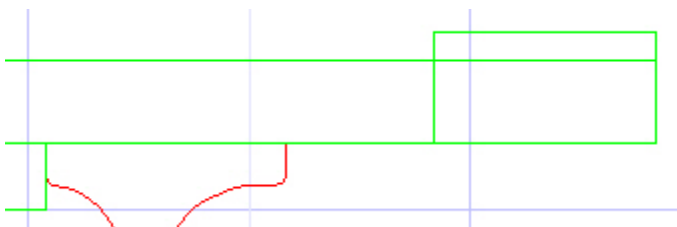
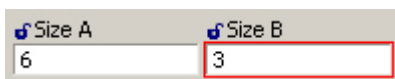

Move the cursor around the arc and I SEKE snap at the intersection of the green circle and the blue angled line.

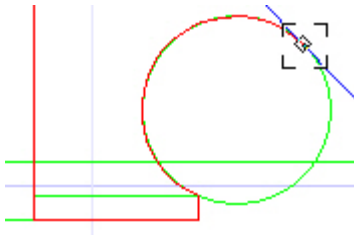

Right mouse click and select Line from the local menu.

Right mouse click again and select Close from the local menu.

Press the Space Bar to exit the tool.

Select the 4.5" circle and then select Coral from the color dropdown menu on the Property toolbar.



Press Ctrl + K to open the Select by Colors dialogue. Select Green and click OK.

Press Delete to remove the trace aids.

Select the Fillet tool from the Modify toolbar.

Tab into the Inspector Bar and enter 1 in the Radius field. Press Enter. Be sure that the To Polyline option is engaged.



Using left mouse clicks on the lines that comprise the corner, fillet the single corner, as indicated in the picture below.

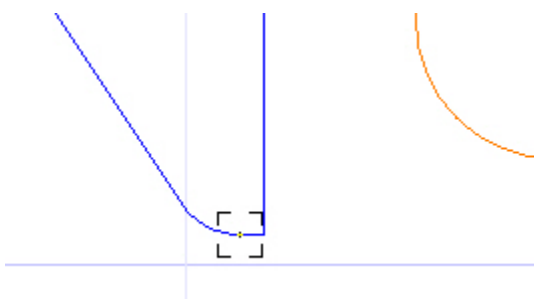

Tab into the Inspector Bar and enter 4 in the Radius field. Press Enter. Be sure that the To Polyline option is engaged.



Using left mouse clicks on the lines that comprise the corners, fillet the single corner, as indicated in the picture below.

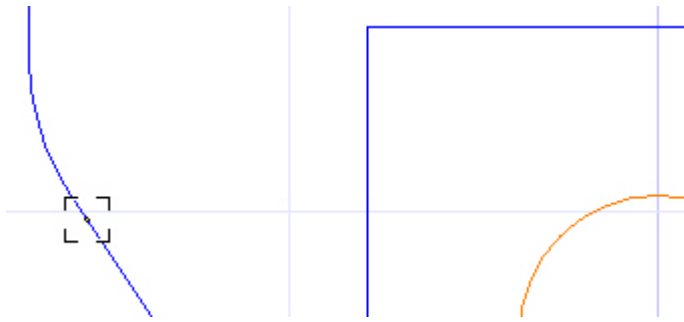

Tab into the Inspector Bar and enter 6 in the Radius field. Press Enter. Be sure that the To Polyline option is engaged.



Using left mouse clicks on the lines that comprise the corner, fillet the single corner, as indicated in the picture below.

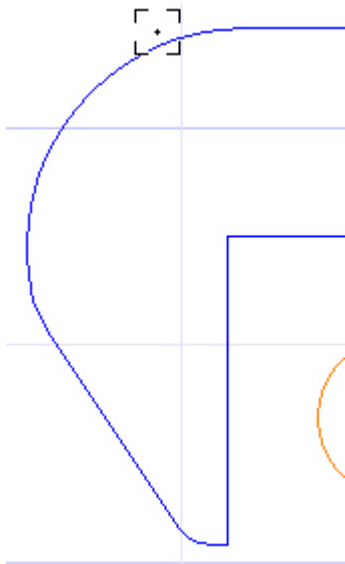

Tab into the Inspector Bar and enter 2 in the Radius field. Press Enter. Be sure that the To Polyline option is engaged.



Using left mouse clicks on the lines that comprise the corners, fillet the three corners of the triangle, as indicated in the picture below.

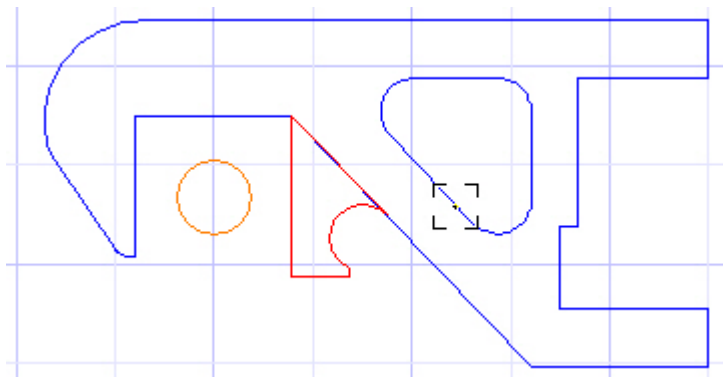

Select and delete the 5" line.

Switch to Isometric SE view.

Select the Lofting tool from the 3D Object toolbar.



Select the two main blue side profiles as the entities to loft.

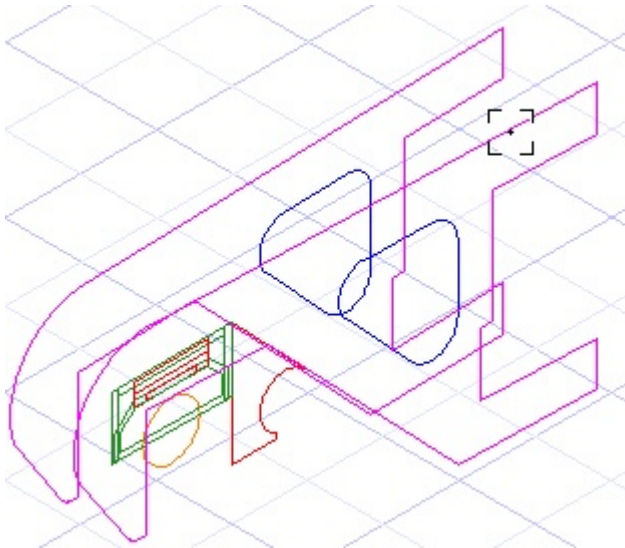

Select Finish.

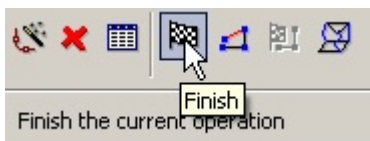

Select the two triangular blue profiles as the entities to loft.

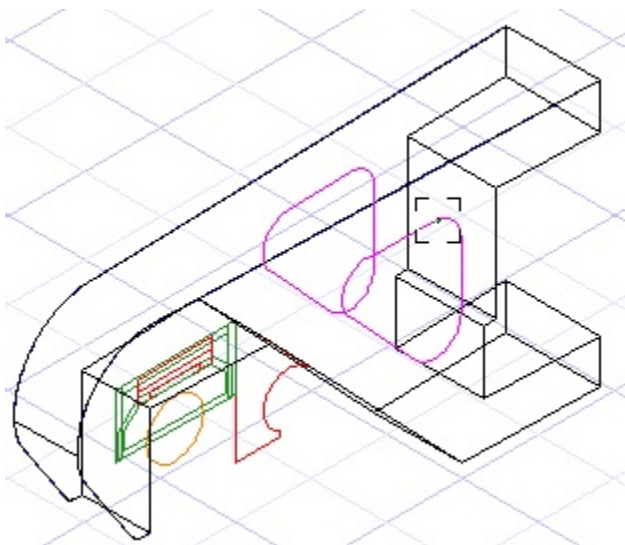

The odd shaped extrusion will now be shelled.

Switch to Isometric NW view.

Select the Shell solid tool from the 3D Modify toolbar.

The Thickness field should still read -0.125 in.

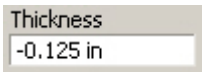

Select the odd shaped extrusion as the object to shell. Place the cursor over the inner cup and when it is highlighted left mouse click to select it as a face to omit. In progress below.

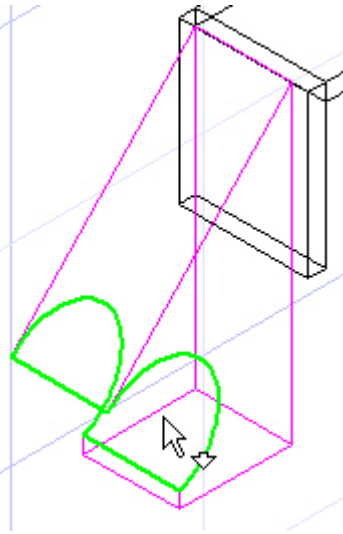

Place the cursor over the lower rectangular face and when it is highlighted left mouse click to select it as well, as a face to omit. In progress below.

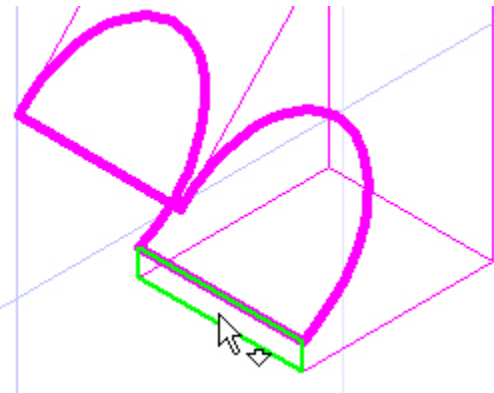

Place the cursor over the side of the extrusion, as indicated in the picture below, and press Page Down on the keyboard to move to the 'hidden' facet. When it is highlighted left mouse click to select it as well.

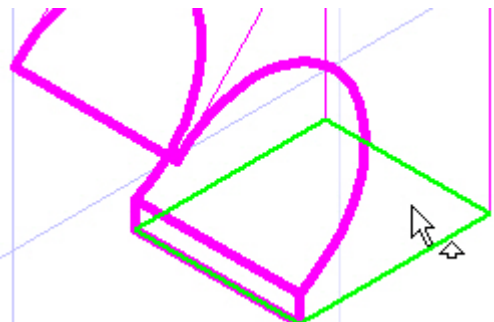

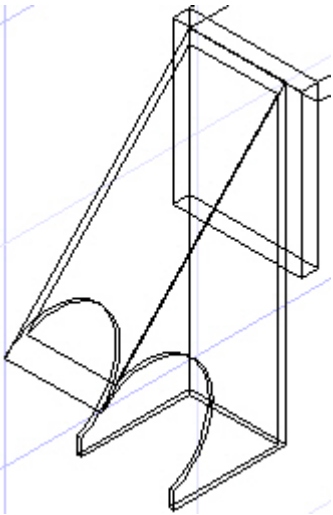
**Select Finish.**

Press the Space Bar to exit the tool.

Select the four on-screen objects and assign them to the Side Frame layer.

Turn on the Bearing Adapter layer.

Select the Fillet Edges tool from the 3D Modify toolbar.

Tab into the Inspector Bar and enter 1/16 in the Start Radius field. Press Enter.

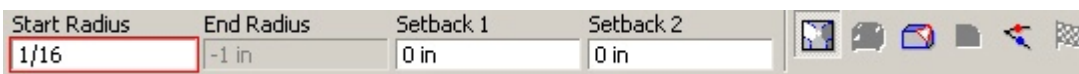

Select the larger component of the bearing adapter as the object to fillet.

Switch to World Plan view.

Drag the selection cursor around the right edge nodes to select them as the edges to fillet. In progress below.

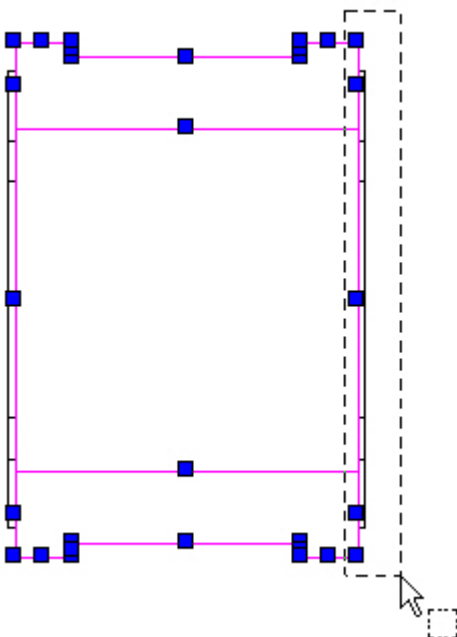

Move the cursor upward .5" and M SEKE snap the top line of the various profiles to define the extent of the move. In progress below.



Select the Polyline tool from the Line toolbar.

Select Blue from the color dropdown menu on the Property toolbar.



Using nine V SEKE snaps and one I SEKE snap place the first ten points of the polyline as indicated in the picture below.

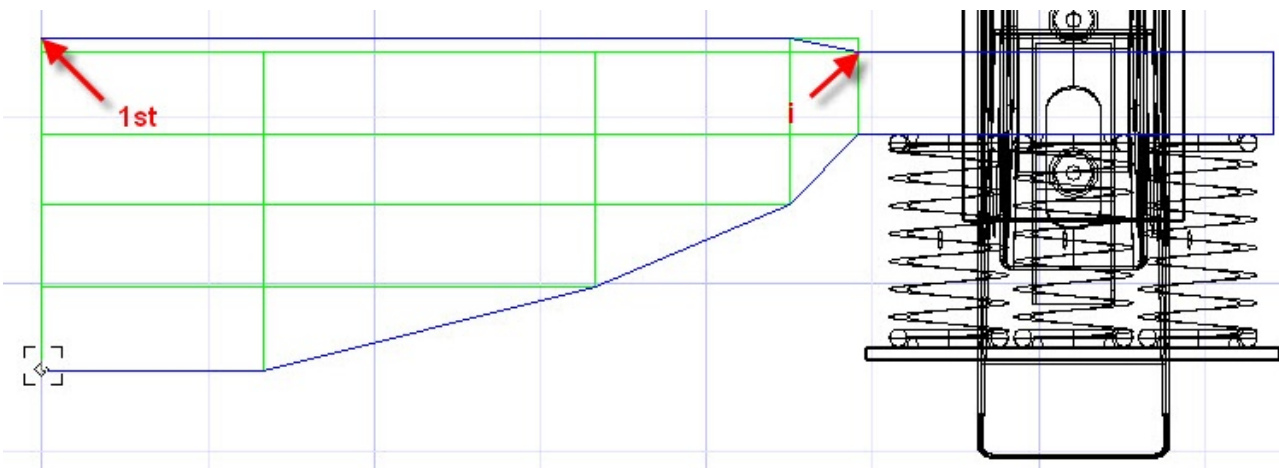

Right mouse click and select Close from the local menu.

Press the Space Bar to exit the tool.

To begin to create two hole profiles, select the 20 x 8.5" green rectangle. Select Blue from the color dropdown menu on the Property toolbar.



With the rectangle still selected, Tab into the Inspector Bar and enter 3 in the Size X field and 7 in the Size Y field. Press Enter. This will become a hole cutting profile.

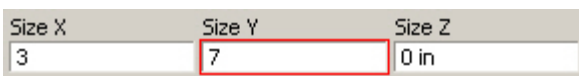

With the rectangle still selected, Tab into the Inspector Bar and enter 10 in the X Position field and 31 in the Z Position field. Press Enter.

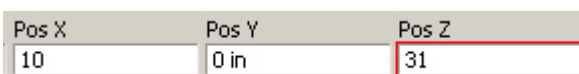

Select the 27 x 6" green rectangle. Select Blue from the color dropdown menu on the Property toolbar.



With the rectangle still selected, Tab into the Inspector Bar and enter 5 in the Size X field and 2 in the Size Y field. Press Enter. This will become a hole cutting profile.

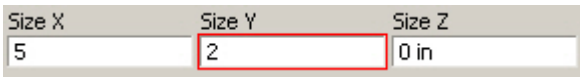

With the rectangle still selected, Tab into the Inspector Bar and enter 19 in the X Position field and 31 in the Z Position field. Press Enter.

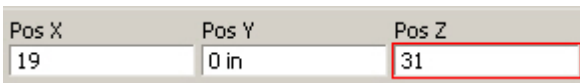

Press Esc to deselect the selection.

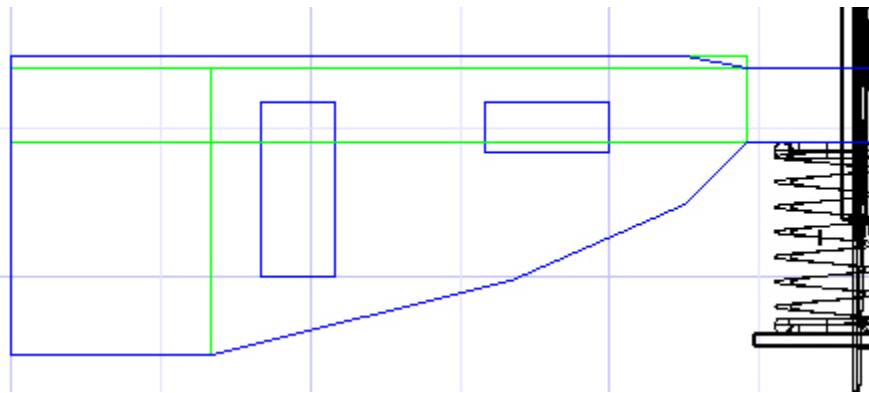

Before deleting the green trace aids and filleting the blue profiles a profile for the bolster bowl will be created.

Select the Polyline tool from the Line toolbar.

Select Red from the color dropdown menu on the Property toolbar.



V SEKE snap the first point of the polyline to the upper right corner of the 8 x 11.5" rectangle, as indicated in the picture below.

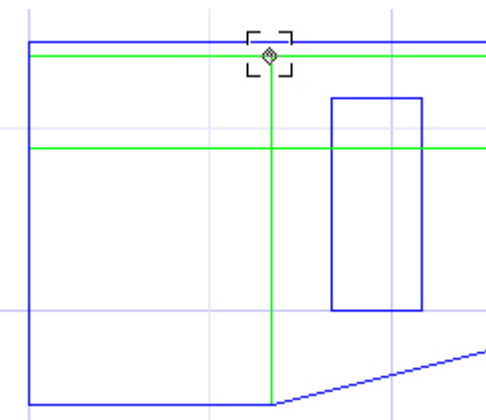

**Q SEKE** snap the top corner of the bowl to define the first point of the mirroring line. Press and hold the Shift key down. Move the cursor upward a short distance and then left mouse click to define the second point of the mirroring line. Release the Shift key. In progress below.

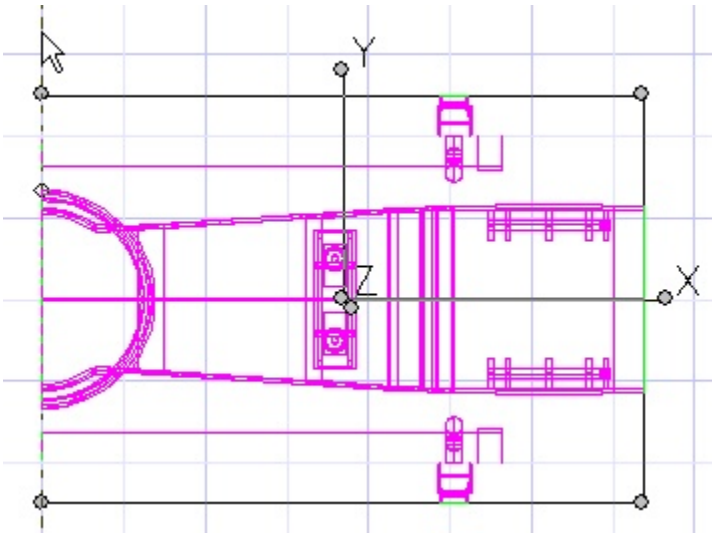

Turn off the four layers en masse. In progress below.

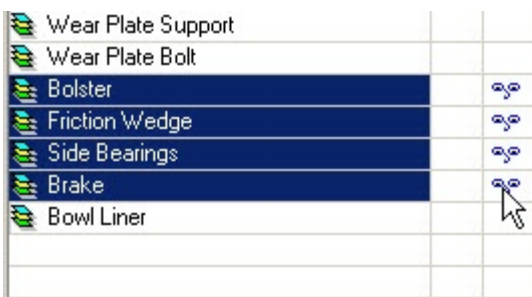

Turn on the Spring Plate layer.

Switch to Left view.

Drag the selection cursor around the upper spring seats to select all eighteen. In progress below.

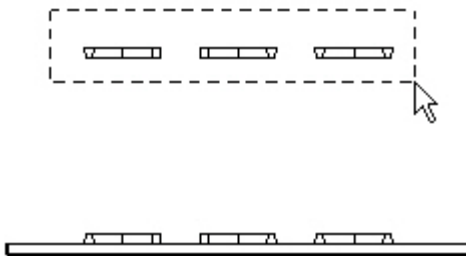

Assign the selection to the Bolster layer.

Turn off the Spring Plate layer and turn on the Friction Wedge and the Bowl Liner layer.

Switch to Isometric SE view.

Except for the twelve small bolt plates of the friction wedge, these are the only non-block parts.

## Materials Application

Because of the number of components in the model and the chamfered and filleted corners that have been applied to objects the drawing is moderately intense. As such, most of the components have been turned into blocks. Materials must be applied to blocks via the Block palette edit function.

In this drawing only six similar materials are being used. They will all be created at the same time and then used as each part is addressed.

Turn off the grid.

Select the four box shaped friction plates.

Open the Properties dialogue for the selection.

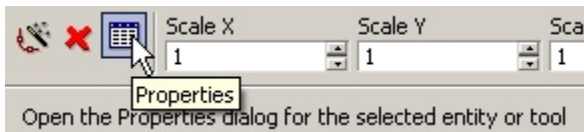

Under the 3D tab select Edit Material.

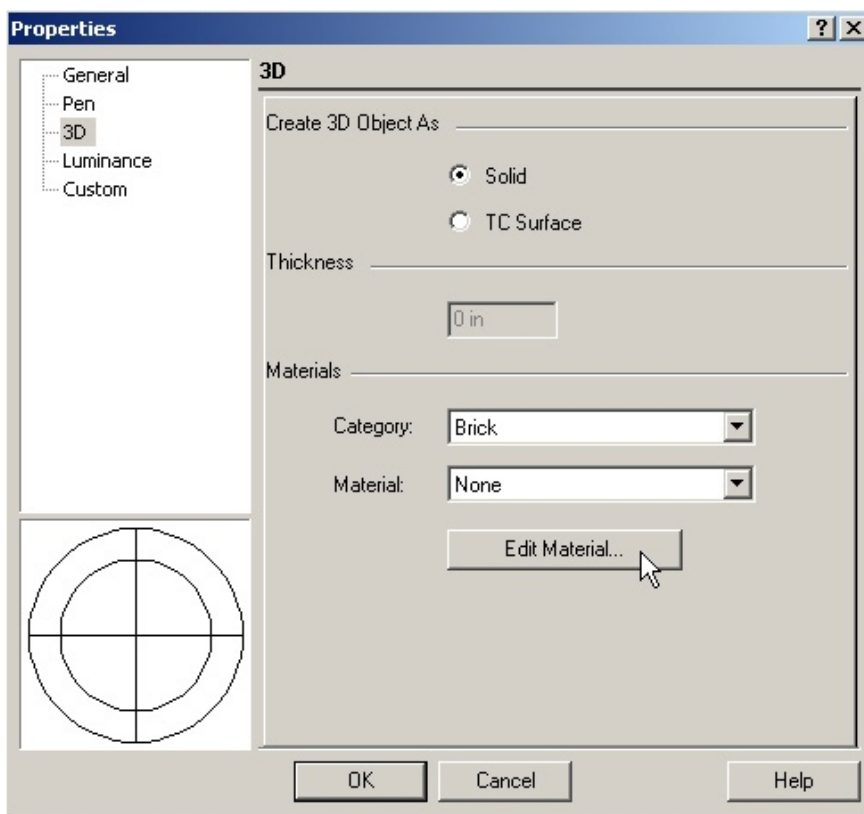

Left mouse click the icon by the Category dropdown menu to create a new Category.

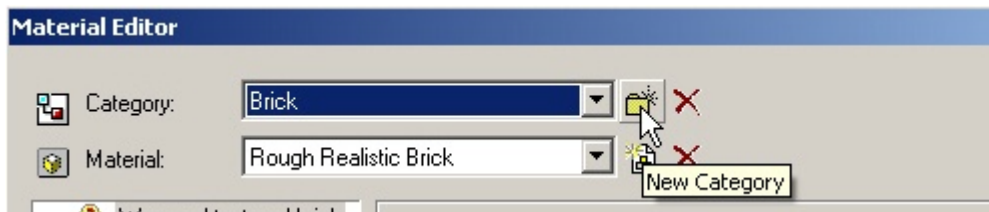

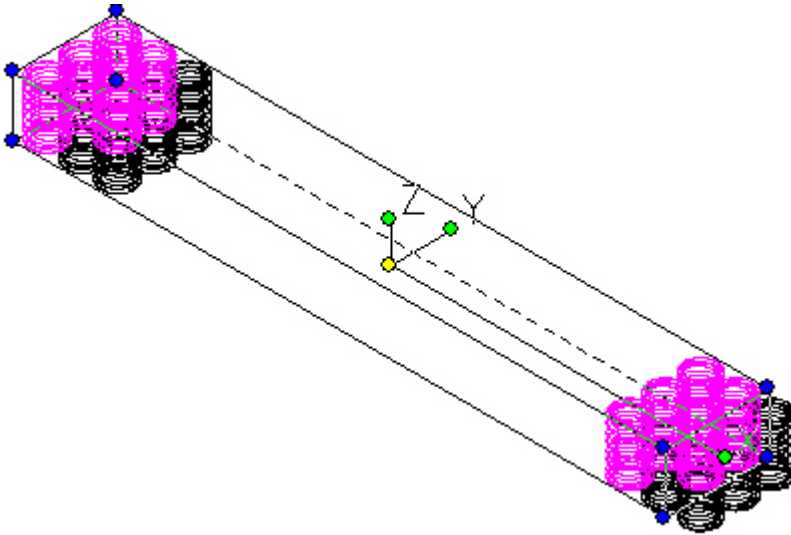

Create a new layer called Hidden Objects and turn it off.

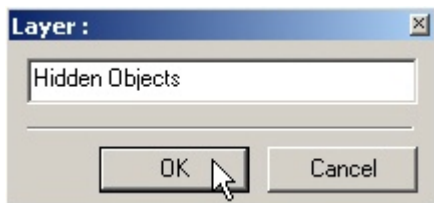

Assign the selection to the new layer.

Turn on all the layers except 2D, Extra Frame and Hidden Objects.

Press Ctrl + A select all the visible components.

Right mouse click on one of the Standard View icons to open the Named View dialogue. Select the name ISO 1 in the Name window and then click Go to. Allow time for the graphics to load. Click Close.

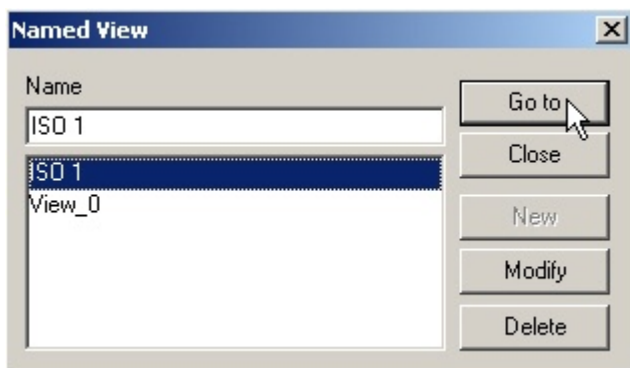

Right mouse click the Wireframe render icon on the Render toolbar to open the Camera Properties. Check Quality. Click OK.

Allow time for the graphics to load and the screen to render (1 minute, 32 seconds on the author's off the shelf HP computer).

Press Esc to deselect the selection after the screen renders.

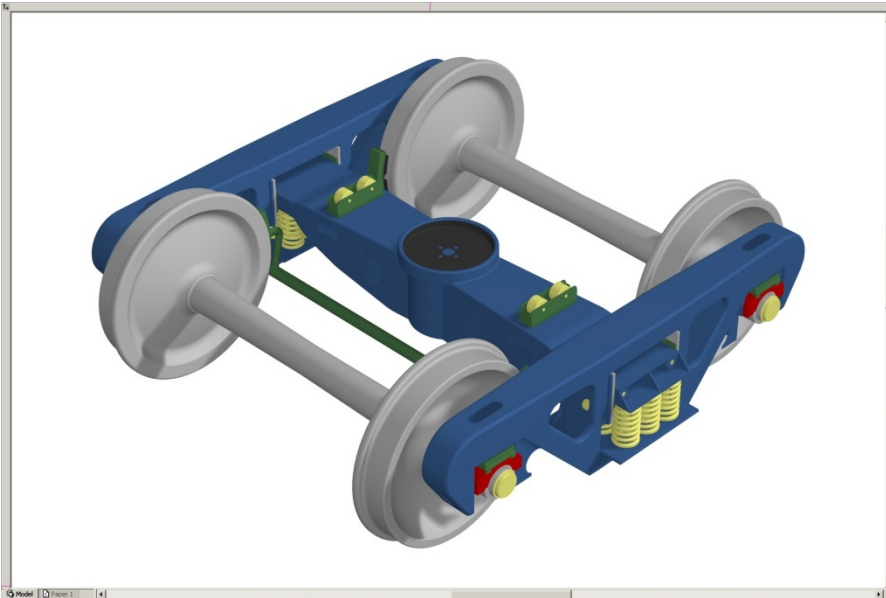

Opening up the task manager it can be seen that the PF Usage is around 1.6 GB. TurboCAD can use about 1.6 – 1.7 under Windows XP so there might be enough memory change the lighting and to save to image format. It will be attempted, so leave the screen rendered.

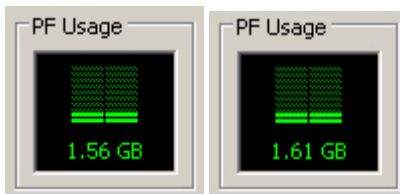

## Render Scene Luminance

Standard lights are often all that is required for a scene, but luminance light can often perk up a scene to the next level. It should be noted that luminance lighting is required if a user requires light to pass through transparent or semi transparent materials.

From the View menu at the top of the TurboCAD desktop select Lights.

Left mouse click on the three light bulb icons to turn off the standard lights. Click OK.

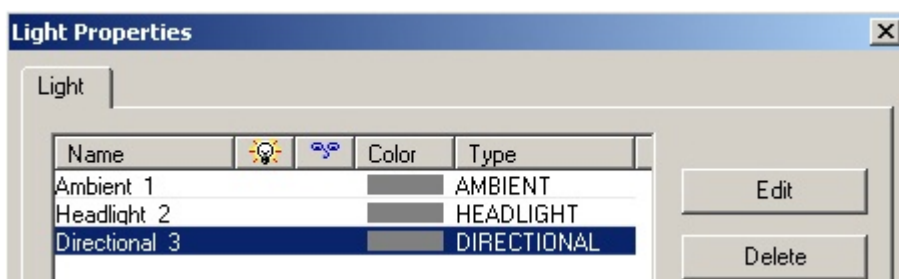

When the screen begins to re-render press Esc to stop the render.

From the Options menu at the top of the TurboCAD desktop select Render Scene Luminance.

Select Single from the Category dropdown menu and select Spot from the Luminance dropdown menu. Select Edit Luminance.

Delta X	Delta Y	Delta Z
-60	0 in	0 in

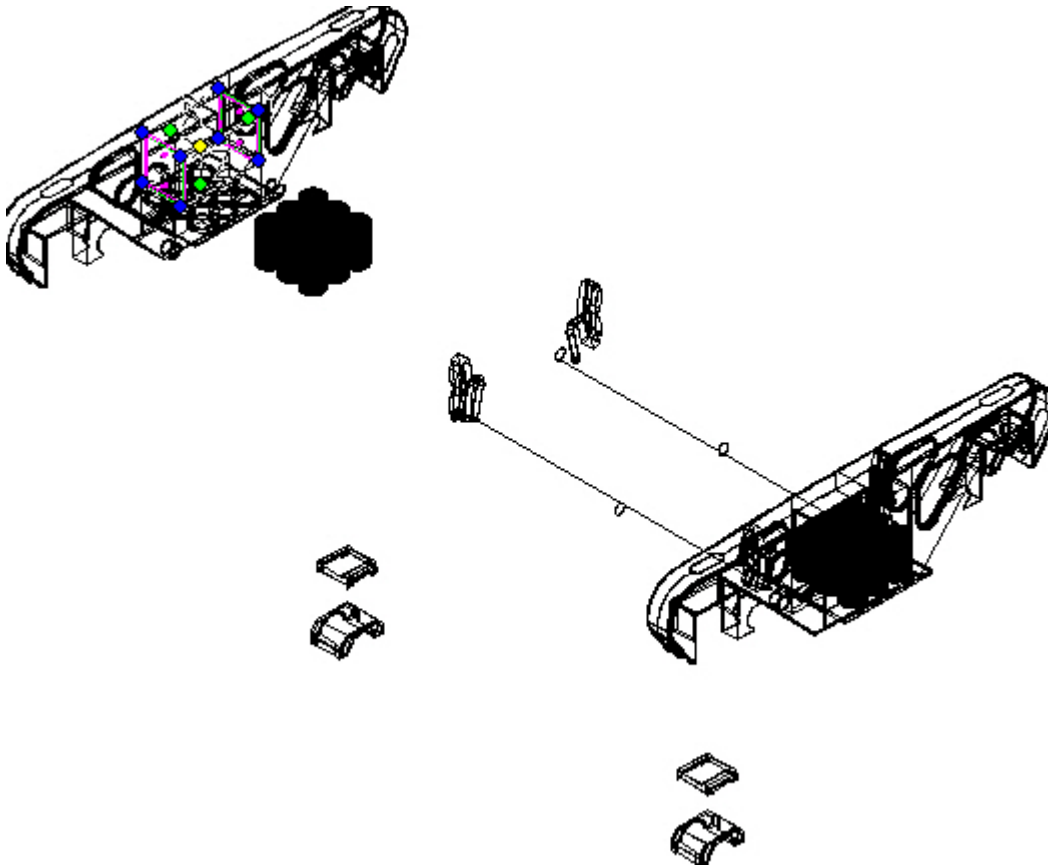

Turn on the Wear Plate and Wear Plate Bolts layers.

Select the two far wear plates and four far wear plate bolts. Tab into the Inspector Bar and enter -13.5 in the Delta X field. Press Enter.

Delta X	Delta Y	Delta Z
-13.5	0 in	0 in

Select the two far right wear plate bolts. Tab into the Inspector Bar and enter 7 in the Delta Y field. Press Enter.

Delta X	Delta Y	Delta Z
0 in	7	0 in

Select the two far left wear plate bolts. Tab into the Inspector Bar and enter -7 in the Delta Y field. Press Enter.

Delta X	Delta Y	Delta Z
0 in	-7	0 in

Turn on the Friction Wedge layer and select the left set that is out in the open.

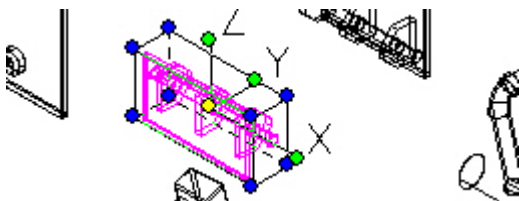

Select the HRI Railcar Truck text block and then Tab into the Inspector Bar and enter **-.15** in the Delta Y field. Press Enter to move it down a short distance.

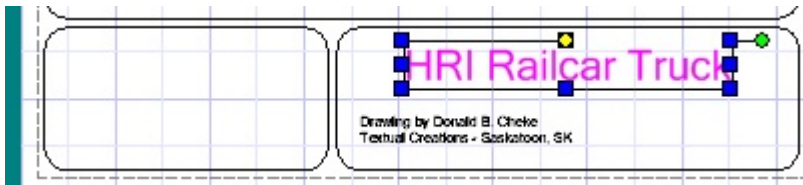
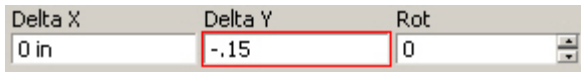

Right mouse click and select Rubber Stamp from the local menu. Move the cursor to the top line at the top of the page and M SEKE snap a copy in place.



Press Esc to exit the Rubber Stamp tool.

Select the upper HRI Railcar Truck text block and then Tab into the Inspector Bar and enter **-.15** in the Delta Y field. Press Enter to move it down a short distance.

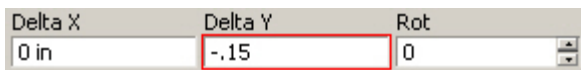

Open the Properties dialogue for the selection.

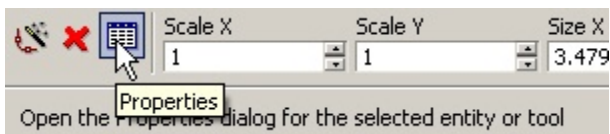

Under the General tab, add Overview at the end of the existing text. Click OK.

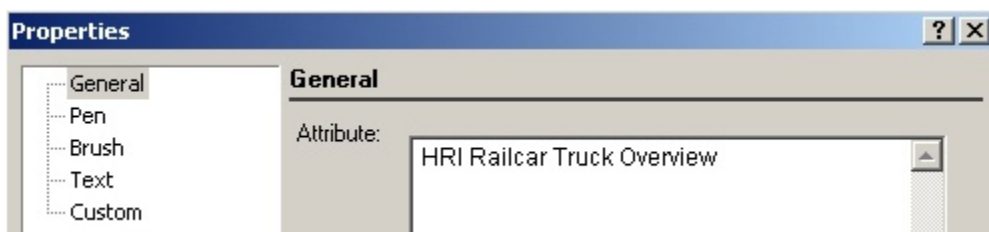

Select the Drawing by... text. Tab into the Inspector Bar and enter **-.15** in the Delta X and Delta Y fields. Press Enter.

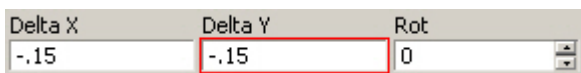

With the Drawing by... text still selected, select the Mirror Copy tool from the Copy toolbar.

M SEKE snap the bottom line of the lower right rectangle to define the first point of the mirroring line. Press and hold the Shift key down. Move the cursor upward a short distance and then left mouse click to define the second point of the mirroring line. Release the Shift key. In progress below.

Right mouse click on the Paper 1 tab and select Duplicate.

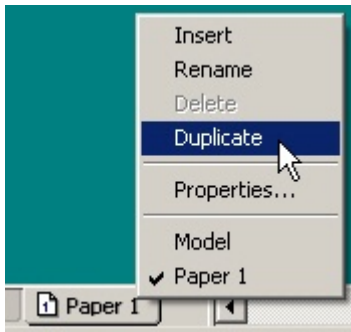

Select the Paper 2 tab.

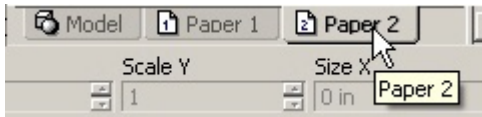

Double click on the page number text block to open the Properties dialogue.

Under the General tab change the text to read 2 of 2. Click OK.

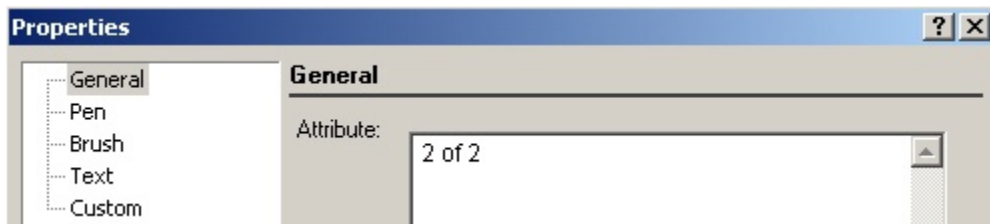

Select and delete the main viewport.

Select the Insert Viewport tool from the Named View toolbar.

Using two G SEKE snaps, place a 7.5 x 8" viewport as indicated in the picture below. In progress below.

